

## Cautionary Tale

### Torsion Spring Stresses; Part 2

Part 1 of this tale questioned whether the classical mechanics formulae for calculating stresses in torsion springs were correct. In part 1 it was shown that the mandrel diameter influenced torque output using the spring shown in figure 1 fitted with strain gauges. The torsion springs were made with a gap between the coils, had tangential legs, used 4mm square spring steel wire. To ensure the test spring was not subject to plastic deformation the maximum deflection was limited to 45 deg / 9.3Nm, equating to a theoretical uncorrected stress of 870MPa, or 52% of the wire UTS.

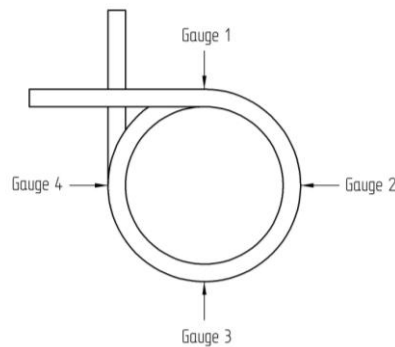

Fig 1 Gauge locations

During testing the spring was supported on interchangeable mandrels of  $\text{Ø}32$ ,  $30$ ,  $25\text{mm}$  diameter. The spring legs were loaded using  $\text{Ø}9\text{mm}$  pins at a radius of  $40\text{mm}$  from the jig centre.

When deflecting to a fixed angle, the torque, and hence stress, was lower when using a smaller mandrel, but the spring visibly sheared producing stresses that were not the same at each of the strain gauge location. The average stress measured with each mandrel was similar, but the difference in max. and min. was much greater with the small mandrel. The stress data for a constant torque will now be discussed.

The strain gauge results were used to calculate the stress for an applied torque of  $8\text{Nm}$ . The results in table 1 show the average calculated for the loading/unloading stresses measured at the four gauges, and they were measured at both the static and driven end of the spring. In theory the stresses at each end should be the same, and to a first approximation this theory was shown to be true in practice. The theoretical CAD stress at  $8\text{Nm}$  is  $749\text{N/mm}^2$  uncorrected, and  $809\text{N/mm}^2$  corrected.



	Mandrel Diameter					
	Ø25		Ø30		Ø32	
	Static	Driven	Static	Driven	Static	Driven
	Angle (Deg) at 8Nm					
	43.5	43.3	40.6	40.8	40.0	39.6
Position	Stress (N/mm <sup>2</sup> )					
G1	856	850	822	814	798	809
G2	915	928	820	796	787	763
G3	685	689	714	711	731	733
G4	626	621	714	741	753	788
<b>Average</b>	<b>771</b>	<b>772</b>	<b>768</b>	<b>766</b>	<b>767</b>	<b>773</b>

Table 1. Stress at the Static and Driven ends subject to a constant 8Nm torque

These results show that with the larger Ø32 and Ø30mm mandrels gauge 1 is the highest stressed position, which is to be expected. However when the mandrel diameter becomes smaller, then the maximum stress position moves to gauge 2 (as would exist for a spring without a mandrel), so that with the Ø25 mandrel, gauges 3 & 4 have a reduction in stresses indicating that the coil shearing is producing an increase stress at positions 1 & 2 and a reduced stress at position 3 & 4. It can also be seen that as the mandrel diameter reduces the maximum stress measured increases.

Since the maximum measured stresses are approximately equal to the calculated corrected stress, it is reasonable to continue to use this calculation method, but beware that the actual maximum stress will be higher than the calculated when a relatively small mandrel is used. However, this work shows that the current method of correcting the calculated stresses in all design standards around the world are flawed, and whilst they give approximately the right result (but only with relatively large mandrels), a new calculation method would be recommended. A new multi-national research project to produce an internationally acceptable formula for correcting torsion spring operating stresses is required.

The moral of this cautionary tale is that the operating stresses in torsion springs could be significantly different from the values calculated in CAD programs, and this may help explain some problems that are encountered with this type of spring.

*Readers are encouraged to contact Mark with comments about this cautionary tale, and with subjects that they would like to be addressed in future tales, by telephone at (011) 44 114 255 3349 or e-mail [m.hayes@springexpert.co.uk](mailto:m.hayes@springexpert.co.uk).*